

**BTI**

81-810 Tamarisk Street • P. O. Box CCCC • Area Code 714, Diamond 7-0477  
BRAD THOMPSON INDUSTRIES • INDIO, CALIFORNIA TEL 714-991-7230 92201

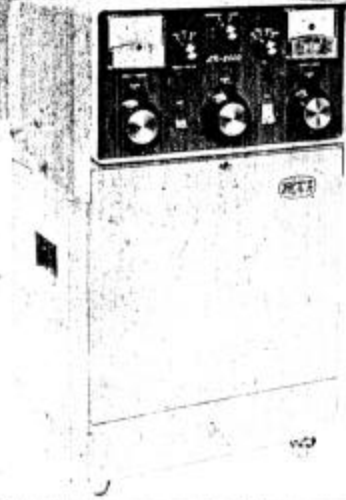

# INSTRUCTION BOOK

## LK-2000 LINEAR AMPLIFIER AND DL-2000 DUMMY LOAD

CALIBRATION

SERIAL NO. 3366

*lean*  
*two lead*

FREQUENCY	TUNE DIAL	LOAD DIAL	PLATE MA.	PLATE VOLTS	GRID MA.	RF. DRIVE	RF. OUT
<i>actual</i> 3900							
7250 <i>730</i>	<i>41</i> <i>38</i>	<i>32</i> <i>35</i>					
<i>9 11</i> 14275 <i>14300</i>	<i>48</i>	<i>22</i>					
<i>11 9</i> 21325 <i>21320</i>	<i>12</i>	<i>12</i>					
28750	<i>15</i>	<i>11</i>					

**NOTE:** Frequencies shown were used for final checkout of your LK-2000. Actual readings will vary somewhat from those shown depending on actual frequency, your antenna and meter. Use the extra space for marking down the settings which you use frequently. This will enable you to retune quickly.

PRICE \$ **100**

	PAGE
Calibration Chart (Cover) .....	1
Installation	
Line Connections - 115 or 230 volts .....	2
Picture of R.F. Section, Top	
Operation	
Connections to Exciter, Antenna	
& DL-2000 Dummy Load .....	3
Loading	
Detail Description	
Picture Front Panel	
Relay & Switching	
Metering .....	4
Fuses, Overload Relay & Door Switch	
A.L.C.	
Picture of Power Supply, Front	
Power Supply Shelf	
Separating R.F. from Power Supply	
Picture of RF-2000 & PS-2000 .....	5

## INDEX

	PAGE
Miscellaneous, Maintenance	
Oil Blower Motor	
Using 4-1000A	
Retuning Input Circuits	
Removing Front Panel	
Sheet Metal Parts	
DL-2000 Dummy Load Instructions .....	6
Parts List .....	7
Picture of Power Supply, bottom	
Picture of R.F. section, bottom .....	10
Drawings:	
2309-110, Rectifier Details .....	11
2309-111, Tuned Cathode Details .....	11
2309-112, DL-2000 Dummy Load .....	6
2309-113, A.L.C. Connection .....	11
2309-108, Wiring LK-2000 .....	11

### GENERAL DESCRIPTION

1. a. The LK-2000 is a single tube, RF linear amplifier with solid state supply, utilizing the 3-1000Z in a grounded grid circuit. It will handle easily the maximum legal power in the amateur bands between 3.5 and 29.7 megacycles. These instructions cover the installation and operation of the LK-2000 console cabinet model. The same procedures apply to the desk top RF-2000 except for the physical placement. Instructions for separating the LK-2000 into two units for desk top operation are given on page 5.

### INSTALLATION

2. a. Set the LK-2000 on the floor beside the operating table. Its furniture casters make it easy to move, even on thick carpeting.
2. b. The 3-1000Z tube and its chimney are packed separately. Unpack the tube and save the warranty slip. It may be needed later if there is a claim for tube warranty. Lift the top cover of the LK-2000. It is released by a quarter turn, slotted latch No. 601-0. Check the HR-8 cooling cap which is shipped with the tube. This cap has eight fins. The set-screw should be tight. If the tube is obtained from another source, be sure to use a cooling cap and chimney as the tube should not be operated without it. Install the tube in its socket. Unpack the SK-516 chimney and install it around the tube. Be sure the chimney is seated around the tube and located by the retaining clips on the chassis. Picture on page 3 shows the location of the parts in the RF section. The chimney is specially shaped to direct cooling air flow around the tube plate cap.
2. c. Loosen the screw which holds the No. 308-29 connector (R-22 & RFC-1) and swing the connector over the tube. Bend it as necessary to align the hole with the screw in the cooling cap HR-8 on the top of the tube. Tighten screws at both ends of the connector. Replace the top cover of the LK-2000 and secure it so as to close the interlock circuit switch S-1-A.
2. d. Connect your exciter output to the RF input jack (Input) of the LK-2000. A length of RG-58/U is supplied. Several types of RF output connectors are used on exciters. None is supplied and you should attach a suitable connector to mate with your exciter.

2. e. Connect a suitable antenna or dummy load to the "Ant." output of the LK-2000. (SO-239 coax connector.)

WARNING: Never operate the LK-2000 nor its exciter without an antenna or dummy load of suitable impedance.

2. f. Connect the "Linear Relay" output of your exciter to the "Relay" terminal of the LK-2000.
2. g. ALC connection and adjustment is described later in paragraph 4 d. During tune up, turn the "ALC Adjust" to full "Up". The ALC adjust is located in the power supply section near the AC line terminals.
2. h. Ground the LK-2000 by connecting a wire of No. 14 or larger size from the "Gnd" terminal to the station ground. Refer to the ARRL Handbook chapter "Assembling a Station" for instructions on grounding and other safety practices.
2. i. Connect the LK-2000 power supply input terminals to the a-c line. A 3-conductor cord is supplied. Unless otherwise specified, this cord is connected for 230 volt operation. Alternate connections for 115 volts are shown. The LK-2000 may be used on the average convenience outlet in a house provided there is little other load on the circuit. Power required is 15 to 16 amperes at 115 volts or 7 to 8 amperes at 230 volts. The 230 volt supply is preferred and recommended. (Note: Primary current may double these values during tune up.)

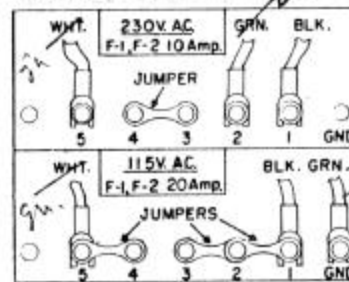

115/230V Line Connections

FOR THAT

# "Extra Class"

YOU NEED The BTI  
LK-2000 LINEAR AMPLIFIER

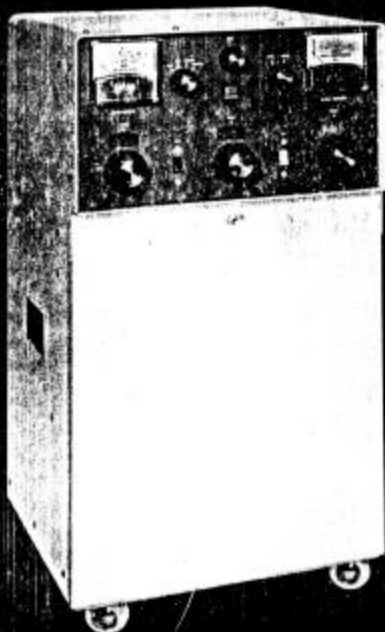

BTI LK-2000 LINEAR AMPLIFIER

\$795<sup>00</sup> Complete



### Features

**REAL SIGNAL IMPACT** with maximum legal input all modes, 2000+ watts PEP SSB, 1000 watts CW-AM-RTTY.

**FULL 1000 WATTS** plate dissipation with rugged 3-1000Z triode by Eimac.

**DEPENDABLE** operation with high quality components.

**FULL LOADING** on all amateur bands 80-10 meters.

**CONVENIENT** band switching, control and metering.

**EASY** to load and tune all bands.

**MORE AND CLEANER TALK POWER** without flat topping with adjustable ALC on RF panel.

**EFFICIENT** grounded grid, zero bias linear circuit.

**INSTANT** transmit—no warm up wait with solid state power supply.

**COMPATIBLE** with most modern transceiver excitors.

**BROADBAND** tuned cathode inputs for all bands.

The BTI LK-2000 is also available as an RF-2000 table top model with a remote PS-2000 power supply. The 3000 volt 1000 ma power supply may be purchased separately by those preferring to build their own amplifiers. Well-engineered, fool-proof, simple operation, reasonably priced, fully guaranteed, the BTI Linear Amplifier provides the signal impact you have been waiting for.

Send \$1.00 for beautifully illustrated technical and instruction manual. Contact your distributor

BTI Amateur Division

**HAFSTROM TECHNICAL PRODUCTS, Inc.**

4616 Santa Fe Street

San Diego, California 92109

Phone (714) 274-8822

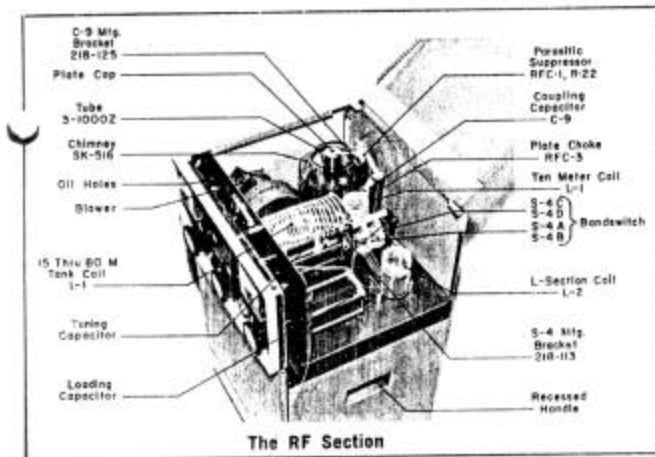

**CAUTION: DO NOT BLOCK THE INTERLOCK SWITCH.** High voltages in the LK-2000 are lethal. **BEFORE LIFTING THE TOP COVER, TURN OFF THE POWER.** Wait for the power supply capacitors to discharge. This can be observed on the multi-meter with the multi-meter switch in KV position.

**DISCONNECT THE A-C LINE CORD BEFORE REMOVING THE SAFETY COVERS IN THE POWER SUPPLY.** Always replace these safety covers before re-connecting the A-C line.

**BEFORE TOUCHING ANY PART OF THE CIRCUIT, SHORT A HIGH VOLTAGE POINT DIRECTLY TO GROUND, USING AN INSULATED HANDLE SCREWDRIVER.**

**OPERATION**

3. a. With power switch off at the LK-2000, tune and load the exciter in the usual manner. (In this mode the exciter bypasses the LK-2000 and may be tuned and loaded directly into the antenna or dummy load at the output of the LK-2000. The output of the exciter may be observed on the multi-meter with the multi-meter switch in RF position. Set a suitable range on the RF switch — either 100 or 1000 — depending on the power output of the exciter.

3. b. Reduce the exciter output to zero, or nearly zero, and set the dials of the LK-2000 as follows:

**ANTENNA/LOAD to Antenna.**  
 Note: If the DL-2000 dummy load is being used, set this switch to Load.  
**MULTI-METER SWITCH to RF.**  
**RF SWITCH TO 1000 BAND, TUNE & LOAD.**  
 Set these to positions indicated on front cover.

3. c. Switch the power on to the LK-2000 by pressing the "On" button. This turns on the dial lights and keys the antenna relay to put the exciter output into the LK-2000 input and the LK-2000 output into the antenna. It also bypasses the standby resistor R-13. The plate milliammeter on the LK-2000 should indicate 175 to 200 milliamperes with no drive.

3. d. Increase exciter drive until there is an increase in LK-2000 plate meter to about 400 milliamperes. Rotate the Tune dial a few divisions either direction for a dip in plate current and peak RF output. The RF meter should show maximum indication at the dip in plate current. (This assumes a resistive load at the antenna post. If the load is reactive the dip may not coincide with maximum RF indication.)

**WARNING:** Do not run the tube above 400 milliamperes plate current without normal RF output. To do so may exceed the plate dissipation rating of the tube and damage it. An rated dissipation the plate will show bright red or orange color. Bright yellow indicates excessive plate dissipation.

3. e. Rotate the load dial slightly in the direction which increases the RF meter indication and re-dip the tuning. **NOTE:** Sometimes no increase in RF will show until the tune is re-dipped. This condition is most noticeable in the higher frequency bands. In such case, adjust the load control slightly in one direction and re-dip the plate. Then adjust the load in the opposite direction and re-dip. If output increases with either direction, continue to adjust the load slightly in that direction and re-dip for maximum output. On higher frequencies the load control is quite critical.

3. f. Increase the exciter drive gradually for maximum RF output while adjusting load and tune dials as above. If the RF meter goes off scale, switch to the 2000 range. If the meter goes off scale on the 2000 range, the antenna or load impedance is too far off. Substitute a dummy load of 52 ohms for tune-up and loading. The DL-2000 dummy load may be attached to the back of the LK-2000 and switched from the front panel. A dummy load should always be used during tune-up and other transmitter adjustments.

3. g. Check the grid current occasionally while making the above adjustments by turning the multi-meter switch to MA position. Grid current should be about 1/3 the value of the plate current. If too high or too low, re-adjust the loading and tuning.

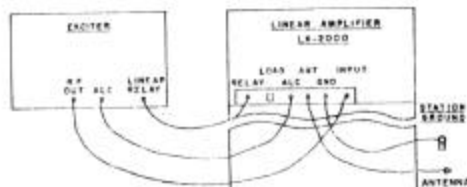

**LK-2000 Rear Connections**

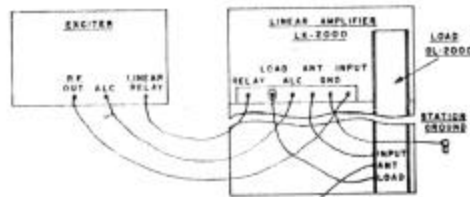

**Connections to DL-2000 Dummy Load**

## LOADING

4. a. For SSB operation the amplifier is loaded as above to about 700-800 milliamperes and maximum RF output. It is possible to load the amplifier beyond maximum RF output. This is not desirable. Low power exciters may not supply sufficient drive to load to maximum power. In such case load for the maximum output which can be achieved with the drive available. The calibration table on the front lists the exciter drive and meter indications for 2 KW power input to the plate.
4. b. **NOTE: This loading can be done legally only into a dummy load.**
4. c. When loaded to about 2 KW input as above, voice peaks will be about 2 KW PEP depending on voice and drive.
4. d. **ALC:** Connect the ALC terminal of the LK-2000 to the ALC input connection of the exciter. If there is no ALC connection provided, make the connection to the grid of the RF amplifier or mixer stage as shown in drawing No. 2309-113. Tune and load both the exciter and LK-2000 as described before. (The ALC adjust in the power supply should be turned full "Up" during tuning). While speaking into the mike, raise the mike gain to the point where flat topping occurs in the LK-2000 output. Turn the ALC adjust "Down" just enough to stop flat topping. This adjustment can be made while watching the output pattern on a scope. Further discussion of the ALC and its advantages appears in the Detail Description Section in paragraphs 9a, b, c.
4. e. For CW operation, tune, load and drive as above to about 370 milliamperes.

## DETAIL DESCRIPTION

5. a. RF input from the BNC connector goes through capacitor C-23 to a section of the antenna relay, RL-2. This relay receives its coil power from a 12 volt DC source in the power supply section. It is keyed by grounding the "Relay" input terminal. Most exciters have a Linear Relay output connection to accomplish this. In the released mode, RF from exciter is conducted through this relay to the "Antenna" output and into the antenna or other load. When this relay is keyed, RF from the exciter is conducted to the tuned Pi cathode circuit of the 3-1000Z amplifier tube.
5. b. A tuned Pi cathode input circuit is employed for ease of drive and minimum distortion. Individual Pi tank circuits are selected for each band with a section of the band change switch. Refer to drawing No. 2309-111. A bi-filar wound filament choke, RFC-4, isolates the RF in the cathode from ground.
5. c. The plate of the 3-1000Z is shunt fed through RFC-3. Coupling capacitor C-9 conducts RF to the Pi-L plate tank and antenna network.
5. d. The power supply consists of the main power transformer T-1 and the voltage doubling rectifier circuit X, C & R. Details of this circuit are shown in drawing 2309-110. The transformer primary consists of two identical windings which are series connected for 230 volt operation and parallel connected for 115 volts line. The secondary is rated 1250 volts at 1.6 amperes. This develops 3400 volts in the standby mode with only the 200 K bleeder resistors as load. In the keyed mode with no drive the load is about 200 milliamperes and voltage 3000. At full load of 800 milliamperes the voltage is 2600. These figures will vary depending on local line voltage. Resistors R provide a bleeder of 200 K ohms. Capacitors C provide 30 Mf to withstand instantaneous voice peaks of SSB.

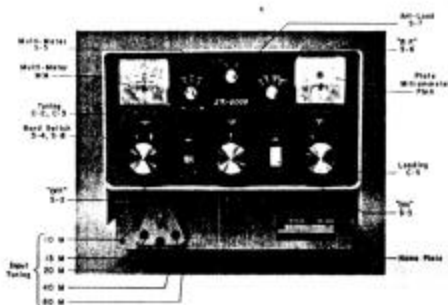

## RELAY & SWITCHING CIRCUITS

6. a. The "On" button closes a circuit from the a-c line to the primary of relay supply transformer T-3. This keys the main power relay RL-1 and the holding relay RL-3. A separate set of contacts on RL-3 starts the blower to provide cooling air flow around the 3-1000Z. RL-3 also closes a circuit to light the tube filament and the dial lamps.
6. b. If the top cover interlock switch S-1-A is open the dial lights and tube filament will come on but the main power relay will not close and neither will holding relay RL-3.
6. c. Standby current of the 3-1000Z is reduced to a few milliamperes by a 50 K resistor in the filament center tap. It is bypassed by action of the antenna relay RL-2 during transmit.
6. d. To turn off the amplifier, press the "Off" button. This opens the relay holding circuit and turns off all power in the amplifier except the blower. Operation of the blower is continued for a minute or more by the Amperite relay 115N059 to provide "After Cooling" and prolong tube life. The 115N059 is a special relay with quick close — delayed open characteristics.
6. e. The Antenna/Load switch provides front panel switching from the antenna to a dummy load such as the DL-2000, or similar unit having a changeover relay. Typical wiring connections are shown in Drawing 2309-112. A thermostwitch in the DL-2000 dummy load is connected across the Antenna/Load switch as shown to shut down the LK-2000 if the load exceeds its rated temperature.
6. f. Other loads may be used. The change over relay should operate on 115 volts AC. If no thermostwitch is used, connect a jumper wire across terminals 2 & 3 of the 6-terminal connector to the Load.

## METERING CIRCUITS

7. a. Plate current is measured on milliammeter PMA which, with its shunt R-8 and calibrating resistor R-9, is connected between the filament center tap and negative high voltage in the power supply. Grid current is measured by Multi-Meter MM which, with its shunt R-11 and calibrating resistor R-12 is connected between the filament center tap and ground.
7. b. RF power is metered by sampling the antenna output through resistive voltage divider R-19 and R-20. Diode CR-1 rectifies this and the DC component is carried through the RF range resistor R-15, R-16, R-17 and R-18 to the RF position on the multi-meter switch and on to the multimeter. This is a relative power indication and readings may vary depending on the VSWR and impedance of antenna, feedline or load.
7. c. Plate voltage is measured on the multi-meter with switch in KV position.

#### FUSES, OVERLOAD RELAY AND DOOR SWITCH

8. a. The primary of the high voltage transformer T-1 is fused by two 10-ampere fuses at F-1 and F-2. (For 115 volt operation use 20 ampere fuses at F-1 and F-2). There is a 5 ampere fuse F-3 in the filament transformer and blower circuit. There is a 2 ampere fuse F-4 in the primary of the relay supply. An overload relay in the high voltage negative return limits plate current to about one ampere. Contacts on this relay open the power relay holding circuit when current exceeds this value. It is reset by pressing the "On" button. S-1-A is a safety interlock switch to prevent the high voltage coming on while the top cover is open. S-1-B is a shorting bar to assure that the power supply capacitors are discharged when the top is open.

#### ALC AUTOMATIC LEVEL CONTROL

9. a. ALC voltage is picked up from the plate tank circuit through capacitive voltage divider C-7 and C-8. It is rectified by diode CR-2 and fed to the ALC jack through a filter consisting of C-6 and R-14. C-6 regulates the time constant of the ALC response. Bias voltage for the ALC is taken from a low voltage tap on the power supply bleeder resistor R, through a voltage divider consisting of a fixed resistor R-4 and potentiometer R-5. RF is blocked out of the bias circuit by RFC-2 and the .01 bypass C-12.
9. b. Most modern exciters have provision for connecting the ALC feedback from the linear amplifier to the ALC circuit in the exciter. If this is not available the ALC voltage may be applied in the manner shown in drawing 2309-113. For more data on ALC circuits refer to ARRL booklet, "Single Side Band for the Amateur" 4th edition, page 246.
9. c. The LK-2000 linear amplifier will take the output of modern SSB exciters from 50 to 200 watts PEP. Distortion and flat topping with this amplifier usually occur in the exciter. The ALC used in the LK-2000, when correctly adjusted, will prevent such distortion from overdriving. The adjustment is outlined in paragraph 4.d. in the tune up section.

#### POWER SUPPLY SHELF

10. a. The shelf in the power supply section may hold your exciter power supply or other gear. An unused outlet for 115 volts AC is provided.



#### SEPARATING THE RF & POWER SUPPLY SECTIONS

11. a. Take out the screws around the top edge of the power supply cabinet No. 301-73. Do not remove the screws in the perforated wall of the RF section for this separation.
11. b. Remove the front door from the power supply section.
11. c. Be sure the power cord is disconnected from the AC line.
11. d. Disengage two cables which plug into the bottom of the RF section. One of these cables has a 12-pin Cinch-Jones connector. Pull it straight out. The other is removed by turning counter-clockwise.
11. e. Lift the RF section out of the power supply section.
11. f. Use extension cables 301-74 (High Voltage) and 301-75 (control) to connect between the RF and power supply sections.
11. g. To remove the cabinet wall from the power supply, first remove the bottom plate (with casters). This will expose the Tinnerman fasteners on the screws around the bottom of the cabinet. Remove these screws. Do not leave any of the Tinnerman fasteners loose in the bottom of the power supply where they might short out a circuit. Replace the bottom plate, either with or without the casters as required.
11. h. A bottom trim No. 2018-46 may be used to cover the exposed parts of the RF section. A top cover No. 315-167 is available to cover the power supply.
11. i. Modification Kit No. 1109-17 includes the extension cables and trim pieces mentioned in f. and h. above. All these items are listed in the accessory section of the parts list.
11. j. If preferred, the power connections in the RF sections may be moved from the bottom and re-located in the back. To do this, remove the bottom plate No. 1612-78 from the RF section. Remove the two connectors from their mounting bracket No. 218-112 and install them in the openings in the back wall of the RF chassis.



RF-2000 RF Section and PS-2000 Power Supply





PARTS LIST LK-2000

Quant.	Description	SUPPLIER	SYMBOL	PRICE
<b>RELAYS, SWITCHES</b>				
1	Relay, DPST-No 12 V coil	Potter Brumfield #PR 7 DY-12 V	RL-1	6.50
1	Relay, 3 PDT 12 V coil	Potter Brumfield #KA14DG-12 V	RL-2	5.00
2	Relay, DPDT 12 V coil	Guardian #905-2C-12D	RL-3 & RL-4	3.00
1	Relay, DPST No 115 V coil	Potter Brumfield PR #7 AY-115 V	RL-5	6.50
1	Thermal Relay time delay	Amperite #115N059	RL-6	4.00
1	Switch, SPST	McGill 2605-1150	SI-A	1.30
1	Switch, Special	BTI #315-178	S-1-B	3.00
1	Switch, SPST N.C. momentary	Carling TILA6L	S-2	1.37
1	Switch, SPST N.O. Momentary	Carling TILA6A	S-3	1.37
1	Switch, Band	Radio Switch #86	S-4	20.00
1	Switch, 1 pole, 3 pos.	Centralab #1461	S-5	1.35
1	Switch, 2 pole, 5 pos.	Centralab #PA1002	S-6	1.86
1	Switch, 2 pole, 2 pos.	#1462	S-7	1.83
1	Switch, 2 pole, 5 pos.	Centralab 2511 or 2504 (modified)	S-8	5.50
<b>MISCELLANEOUS CIRCUIT COMPONENTS</b>				
2	Germanium Diodes IN34A		CR1 & CR2	.75
1	Diode, IN2071		CR3	.85
18	Diodes, IN2071		X	.85
4	Fuse, 1 two amp, 1 five amp, 2 ten amps	Buss ABC	F1 to F4	.15
3	Lamp, 18 V	General Electric 1488		.25
1	Tube, 3-1000Z	Eimac	3-1000Z	78.00
1	Panel Meter 0/200 Microamperes, Dial 0/10/40	A.P.I. Model 302	MM	17.50
1	Panel Meter 0/1 Milliamperes	A.P.I. Model 302	FMA	17.50
<b>PLUGS, JACKS, SOCKETS, CONNECTORS.</b>				
1	Terminal	Millen, 37001-Red	P-2	.60
1	Plug pin	Cinch Jones #P312 DB	P-3	1.25
1	Outlet, Convenience	Smith, 1280-103	J1	.40
1	Terminal	Millen, 37001 Red	J2	.60
1	Connector, 12 pin	Cinch, S312CCT	J-3	1.45
1	Connector	Amphenol UG-1094/U	J4	.81
1	Connector, RF	Amphenol SO-239	J5	.60
2	Jacks, phono	Switchcraft #3501FP	J6 & J7	.25
1	Connector, 6 pin socket	Cinch #S306AB	J8	.56
1	Socket, SK-510	Eimac		6.50
1	Socket, 8 pin, tube	Amphenol #77MIP8		.25
1	Terminal Barrier	Cinch #5-141 Y		.75
1	Connector	Cinch Jones	S308 CCT J9	1.00
1	"	"	P308 CCT P9	1.00



PARTS LIST LK-2000

December 1966

Parts, prices and specifications subject to change without notice.  
 Manufacturer's name and part number for reference only.

*Health Rec of 6.11.67 7 25-2314 @ 2.95*

Quant.	Description	SUPPLIER	SYMBOL	PRICE
<b>CAPACITORS</b>				
8	Capacitors, 240 MF @ 450 V	Mallory #CG241 T450D1	C	3.51
1	Capacitor, 1000 MF @ 25 V	Cornell Dubilier #BR 1000-25	C-1	2.96
1	Capacitor, 1000 MMF Variable, Load	E. F. Johnson #154-30	C-5	25.00
1	Capacitor, Dual 125-125 Variable Tune	E. F. Johnson #154-16 (modified)	C2 & C3	25.00
1	Capacitor, .1 MF @ 50 V	Sprague #TG-P10	C-6	.50
1	Capacitor, Silver Mica 470 PF @ 500 V	Acro DM-19-471	C-7	.35
1	Capacitor, 1.5 MM @ 6 KV	Sprague #60GA-V15	C-8	.40
2	Capacitors, .002 @ 6 KV	Sprague 60 GA-D22	C9 & C11	1.20
2	Capacitors, Silver Mica 220 PF @ 500 V	Acro DM-19-221	C13 & C14	.30
2	Capacitors, Silver Mica 330 PF @ 500 V	Acro DM-19-331	C15 & C16	.33
2	Capacitors, Silver Mica 470 PF @ 500 V	Acro DM-19-471	C17 & C18	.35
2	Capacitors, Silver Mica 910 PF @ 500 V	Acro DM-19-991	C19 & C20	.55
2	Capacitors, Silver Mica 1600 PF @ 500 V	Acro DM-19-162	C21 & C22	.90

**RESISTORS**

8	Resistors 20 W, 25 K		R	1.25
2	Resistors 5 watt, 15 ohm 5%	Wirewound	R1 & R2	.75
1	Resistor 2 watt, 1000 ohm 10%	Carbon	R3	.25
1	Resistor 2 watt, 560K ohm 10%	Carbon	R4	.25
1	Potentiometer, 5 watt, 50 K	Centralab WN 503-50K	R5	2.90
2	Resistors, 2 watt, 1 ohm 5%	Wirewound IRC BWH	R11 & R8	1.25
1	Resistor, 10 watt, 25 ohm	Wirewound	R-10	2.25
1	Resistor, 10 watt, 50 K ohm	Wirewound	R-13	1.25
1	Resistor, 1 watt, 1 Meg. 10%	Carbon	R-14	.20
1	Resistor, 2 watt, 1 K ohm 10%	Carbon	R-19	.25
2	Resistors, 2 watt, 4.7 K ohm 10% &			
1	Resistor, 2 watt, 10 K ohm 10%	Carbon	R-20	.25
3	Resistors, 2 watt, 100 ohm 10%	Carbon	R-22	.25
1	Resistor, 10 watt, 10 ohm	Wirewound	R-24	1.50
1	Resistor, 1/2 watt, 47 K 10%	Carbon	R-26	.20

**TRANSFORMERS, COILS, CHOKES.**

1	Choke, Parasite	BTI, #308-29	REC-1	4.95
1	Choke, RF 2.5 MH 200 Ma	Miller 4537	RFC-2	1.16
1	Choke, RF, 90 UH	BTI #308-28	RFC-3	6.44
1	Choke, Filament	BTI #308-30	RFC-4	6.78
1	Tank Coil	BTI #315-171	L-1	15.00
1	Antenna Coil	BTI #315-172	L-2	14.00
1	Coil 10 meter	BTI #315-177	L-3	5.00
1	Coil 15 meter	BTI #315-176	L-4	5.00
1	Coil 20 meter	BTI #315-175	L-5	5.00
1	Coil 40 meter	BTI #315-174	L-6	5.00
1	Coil 80 meter	BTI #315-173	L-7	5.00
1	Transformer, Plate	BTI #2018-42	T-1	60.00
1	Transformer, Filament	Stancor 6457	T-2	18.80
1	Transformer, Relay	Allied 54D1420	T-3	3.99
1	Transformer Plate, Fil	BTI 2018-53	T1	60.00

PARTS LIST LK-2000

Quant.	Description	SUPPLIER	SYMBOL	PRICE
<b>CABINET AND HARDWARE ITEMS.</b>				
1	Blower	Redmond #AK-4168AX	B	15.25
1	Brace, Front	BTI 218-211		5.00
1	Bracket, Door Latch	BTI 218-114		3.50
5	Bushing, Panel 1/4 shaft	USECO #1560-12		.25
1	Cabinet Console	BTI #301-73		10.00
1	Cable, Band SW output	BTI #301-78		2.50
1	Cable, Band SW input	BTI #301-79		2.50
1	Plate cap, HR-8	Eimac, Div. of Varian		1.65
4	Casters, 2" Ball	Shepard SE-1-BC		2.00
1	Chimney, SK-516	Eimac		12.00
8	Clamp, Capacitor 2-2-1/16	Mallory VR8		.25
2	Coupling, 1/4" shaft	USECO #3316A		.55
1	Cover, Cabinet top	BTI #315-161		5.38
1	Cover, Cabinet Left side	BTI #315-162		5.56
1	Cover, Cabinet Right side	BTI		5.56
1	Cover, Relay	BTI #315-166		2.50
1	Dial Band 10-80	BTI #409-0		3.50
2	Dial Capacitors 0-100	BTI #409-1		3.50
1 set	Fastener, door latch	BTI #601-0		1.50
1 set	Fastener, top latch	BTI #601-1		1.50
4	Fuseholder	Buss HKP		.46
2 sets	Handles, cabinet	BTI #801-11	set/3.00	
1	Hinge, Aluminum	BTI #809-1	ea/3.58	
3	Knobs, 2 1/2"	Kurz-Kash #1312-70-409-7		2.60
3	Knobs, 1 1/4"	Kurz-Kash #1648-3-L-40903		1.30
3	Lampholder, Bayonet type	Leecraft 7-06		.25
2	Latch, covers			
1	Plate, Caster Mounting	BTI #1612-76		8.95
1	Plate, R. F. Bottom	BTI #1612-78		8.95
4	Pulleys, 2 1/2" drive cable	BTI #1612-10		1.75
1	Shelf, cabinet	BTI #1908-33		3.45
1	Standoff, ceramic 0110	American Lava		.35
8	Standoff, ceramic 0112	American Lava		.36
1	Standoff, ceramic 0116	American Lava		.48
2	Standoff, ceramic 0106	American Lava		.32
1	Trim	BTI #2018-44		5.00
1	DUCT coupling	BTI 421-0		2.50
1	clamp for duct	BTI 312-26		.25
<b>ACCESSORY PARTS (OPTIONAL)</b>				
1	Modification kit, for Separating RF section from Power Supply section	BTI #1109-17		34.50
This kit includes the following 5 items, any of which may be ordered separately.				
1	Extension Cable	BTI #301-74		3.50
1	Extension Cable	BTI #301-75		12.50
1	Power Supply Cover	BTI #315-167		7.50
1	Set Plastic feet	BTI #605-4		1.50
1	Bottom trim (RF section)	BTI #2018-46		9.50
1	Connector, 6 pin plug	Cinch #P306CCT		.89
1	Connector	Amphenol UG88 C/U		.85
1	Phono plug	Switchcraft #3501-M		.10
1	extension cable	Filament Leads BTI 301-95		4.00

Pilot Lites CM  
MRR

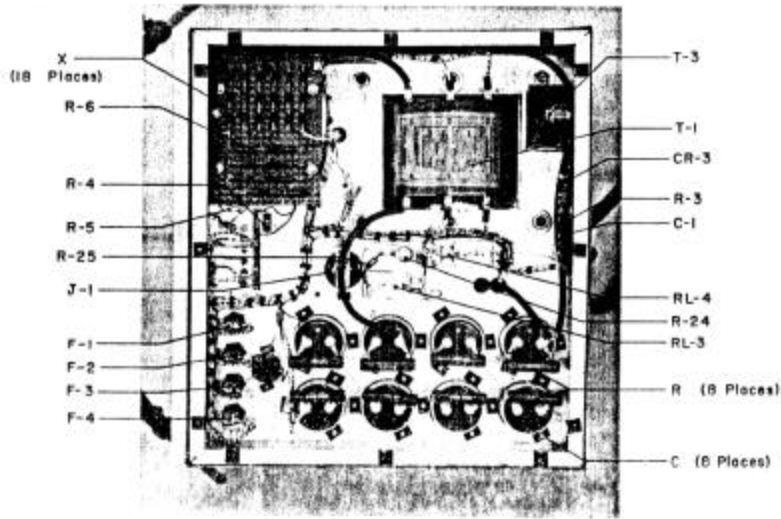

↑  
**Power Supply, Bottom**  
**RF Section, Bottom**  
 ↓

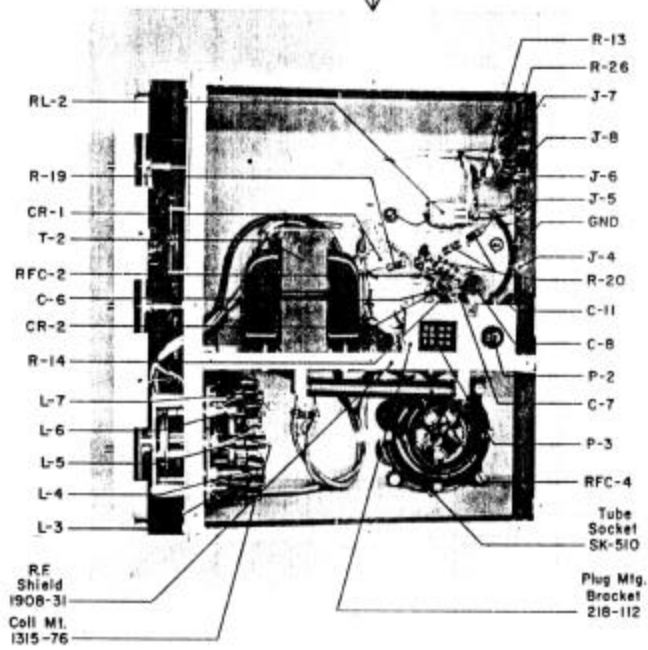

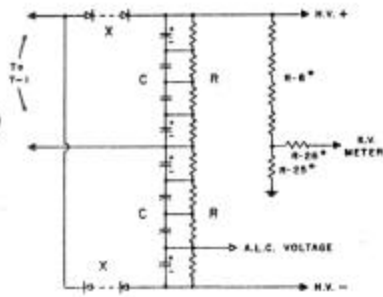

X, X 1N2071 (8 Pieces)  
 C, C 240 MFD 450 V. (8 Pieces)  
 R, R 25K 20W (8 Pieces)  
 \* These Values Selected At Calibration

Rectifier Detail 2309-110

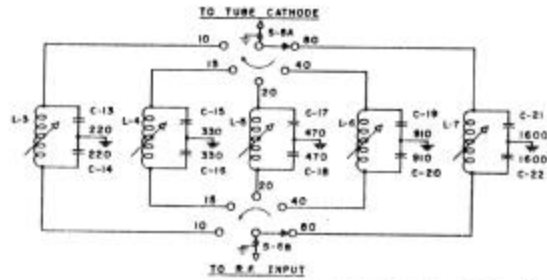

2309-111 Tuned Cathode Input Circuits

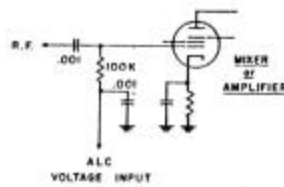

Connecting A.L.C. from the LK-2000 into the Exciter  
 2309-113

Front Panel Laid Down

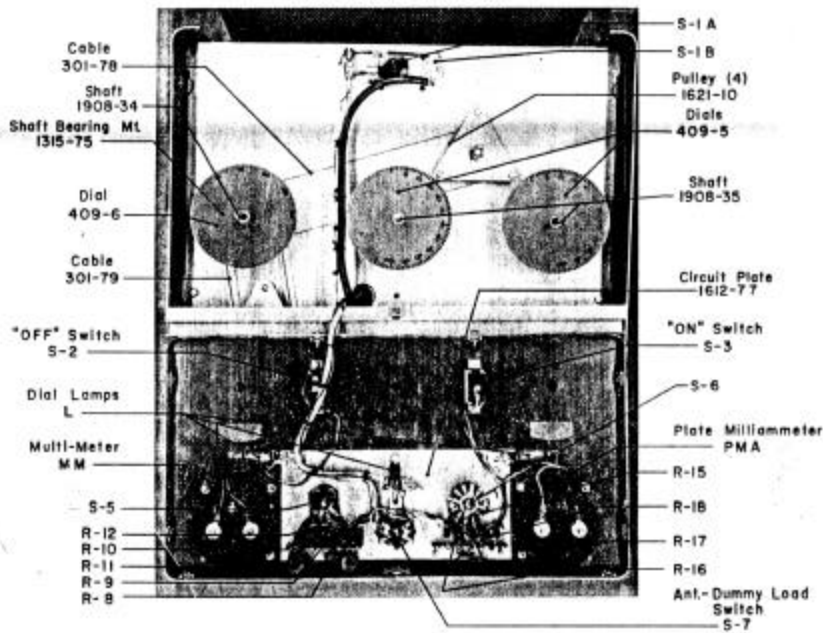

*Handwritten:* M.D.A. 9160-1

**LK-2000  
LINEAR AMPLIFIER**

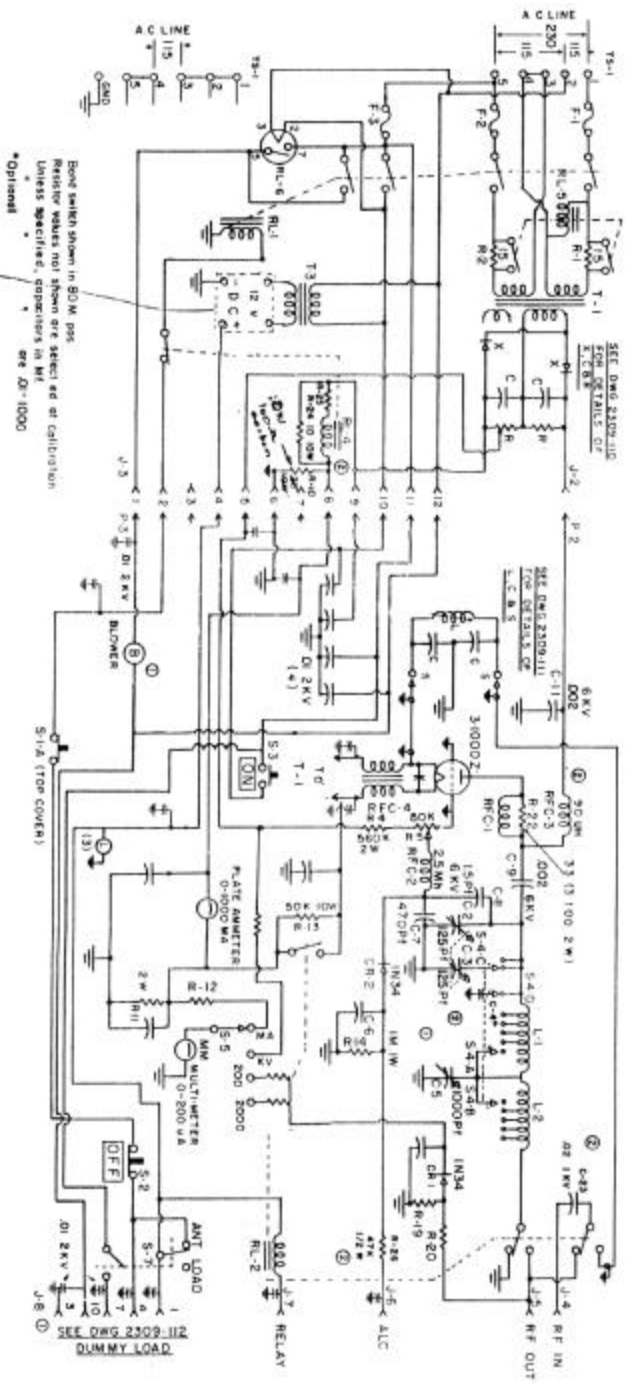

DO NOT SWITCH SHOWN IN BOM pos.  
Resistor values not shown are selected at calibration.  
Values specified, dependent on MI  
are 0E-10000

SEE DWS 2309-112  
DUMMY LOAD

\*Optional

# WARRANTY

BRAD THOMPSON INDUSTRIES, INC., warrants this equipment against defects in material or workmanship for a period of ninety days from date of original purchase, when such equipment is used in normal service for which it is intended.

This warranty does not cover tubes and semiconductor devices.

Do not ship to the factory without prior authorization.

This warranty is limited to repairing or replacing defective parts, and is not valid if the equipment has been tampered with, misused or damaged.

Brad Thompson Industries, Inc., reserves the right to make any changes in design or to make additions to, or improvements in these products without imposing any obligations to install them in previously manufactured products.

*Price and specifications subject to change without notice.*



BRAD THOMPSON INDUSTRIES, INC. BTI AMATEUR DIVISION  
P.O. BOX CCCC Indio, California 92201

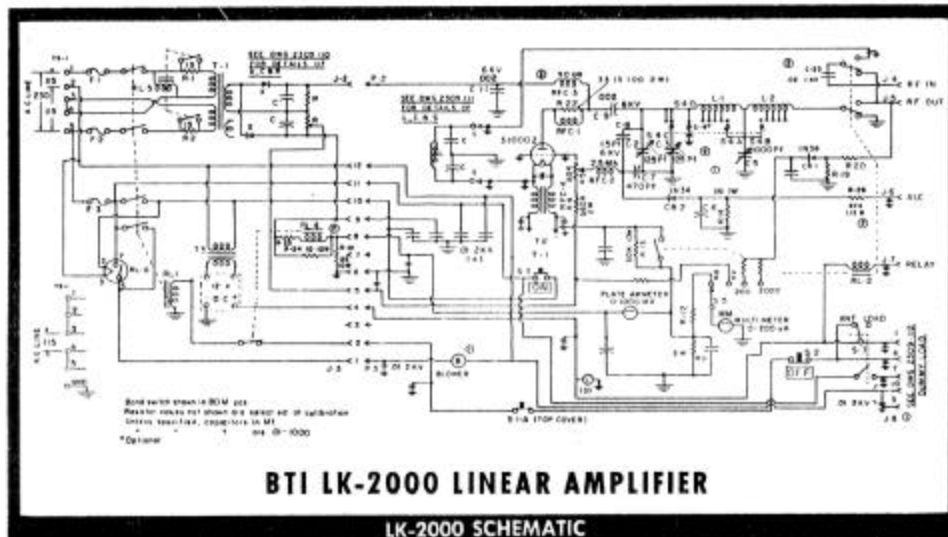

LK-2000 SCHEMATIC

### Specifications

- |   |   |
|---|---|
| Circuit . . . . . Grounded grid, zero bias linear amplifier                           | Color . . . . . Two-tone grey                                 |
| Frequency range . . . . . Amateur bands (and adjacent frequencies) from 3.5 to 30 Mc. | RF chassis and cabinet . . . . . Gold Iridite finish aluminum |
| Drive . . . . . 50 to 200 Watts R.F.  | Power supply section . . . . . Heavy gage steel               |
| Power rating . . . . . 2 KW SSB PEP, 1 KW CW-AM-RTTY                                  | Size and shipping weight:                                     |
| Line voltage . . . . . 115/230 volts, 50/60 Hz, 20/10 Amps.                           | LK-2000 . . . . . 16¼w X 16d X 30h (Inc. casters) 115 lbs.    |
| Tube . . . . . Eimac 3-1000Z (or 4-1000A)   | PS-2000 . . . . . 16¼w X 15d X 12½h (Inc. casters) 75 lbs.    |
|   | RF-2000 . . . . . 16¼w X 16d X 14½h (with feet) 50 lbs.       |

The dummy load is mounted in a steel case and has an aluminum cover measuring 24 X 5½ X 2¼ inches. It must be operated in a vertical position. Though designed for mounting on the rear of the LK-2000 Linear Amplifier it may be used with other amplifiers.

The changeover relay is normally supplied with 115 volt AC coil. A thermo-switch with normally closed contacts is set to open when the load reaches its maximum rated temperature of 220 degrees F. The contacts of the thermo-switch may be used to shut off the power to the load or to actuate a warning device.



**DL-2000 DUMMY LOAD \$ 95.00**

Printed in U.S.A.



**RF-2000**  
The TABLE TOP . . . \$529.50



**PS-2000**  
POWER SUPPLY . . . \$300.00

### Accessories

- 1109-17 MODIFICATION KIT for separating the RF section from the power supply . . . . . \$34.50
- DL-2000 DUMMY LOAD For tuning radio transmitters having power ratings up to 2000 watts input to the final amplifier stage. Includes a changeover relay for switching the transmitter output from the station antenna to the dummy load. . . . . \$95.00

Prices and specifications subject to change without notice.

WRITE DIRECT OR SEE YOUR DEALER

CIRCUIT CHANGES EFFECTIVE WITH SERIAL #3068

The filament supply for the 3-1000Z tube is moved to the power supply section. In the manual disregard any reference to filament transformer T-2 which is not used.

Add or change these items on the parts list:

Page 7. Under "Resistors" Change R-10 from 10-watt, 25-ohm wire-wound to 2-watt, 100-ohm carbon. Price \$ .25

Under "Transformers, Coils, Chokes" Add:  
1 Transformer, Plate & Filament. BTI #2018-53 T-1 \$60.00

Page 8. Under "Plugs, Jacks, Sockets, Connectors" Add:  
1 Connector Cinch-Jones #8308-CCT J-9 \$1.00  
1 " " " #P308-CCT P-9 1.00

Page 9. Under "Accessory Parts (Optional)" Add:  
1 Extension Cable(Filament Leads) BTI #301-95 \$4.00

CHANGE EFFECTIVE WITH SERIAL #3290

The glass chimney for the 3-1000Z tube is replaced with a more effective cooling system. A metal tube conducts cooling air from below the chassis and directs it at the cooling fins on the plate cap of the tube.

Add the following to the parts list:

Page 9. Under "Cabinet and Hardware Items" add:  
1 Duct, cooling BTI #421-0 \$2.40  
1 Clamp (for Duct) BTI #312-26 .25

CABINET CHANGE EFFECTIVE WITH SERIAL #3091

This drawing shows cabinet parts which are different from those shown in the "Cabinet Parts" drawing on page 6 of the manual.

To take off the top cover, remove all the screws in the 1-piece cover #0315-197C and lift it off.

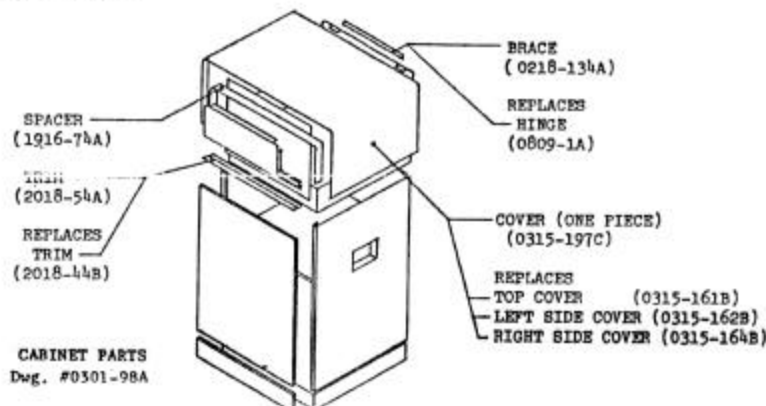

CHANGE EFFECTIVE WITH SERIAL #3335

ALC control transferred from power supply to amplifier panel.



# HAFSTROM TECHNICAL PRODUCTS, INC.

4818 SANTA FE STREET • SAN DIEGO, CALIFORNIA 92109

SUPPLEMENT #3  
BULLETIN LK-2000

## INSTRUCTION MANUAL CHANGES

Section	Page	Paragraph	
Installation	2	2 b	The chimney has been replaced by a more effective cooling jet. Delete references to chimney.
		2 g	The ALC adjust is now located on the RF panel for greater operator convenience.
Operation	3	3 a,b	The RF ranges are selected on the multimeter switch eliminating the requirement of setting two switches.
Relay & Switching	4	6 f	A 12-terminal connector has been substituted for the 6-terminal connector. Jumper terminals 1 & 4 if no thermostat is used.
Power Supply Shelf	5		Shelf and unfused outlet have been eliminated for safety reasons.
Separating RF & Power	5	11 d,f	Add a third cable with 8-pin Cinch-Jones connector for filament connection.
DL-2000 Operation	6		A 12-prong Cinch-Jones connector has been substituted for the 6-prong connector. Pin numbers changed from 2,3,4,5,6 to 1,4,7,10,3 respectively.
Parts list	7		R-3 deleted R-10 now 2-watt, 100 ohm carbon.....\$.25 BTI 2018-42 & Stancor 6457 deleted BTI 2010-53 Plate and Fil trans. added \$60.00 C-1 deleted
		8	CR-3 deleted B-1 Bridge rectifier added.....\$3.00 FMA changed from 0-1 to 0-1000MA.....\$17.50
		9	SK-516 chimney deleted Top, left side, right side & back of cover combined BTI #009-1 deleted BTI 1906-13 deleted

### CABINET CHANGE EFFECTIVE WITH SERIAL #3091

This drawing shows cabinet parts which are different from those shown in the "Cabinet Parts" drawing on page 6 of the manual.

To take off the top cover, remove all the screws in the 1-piece cover #0315-197C and lift it off.

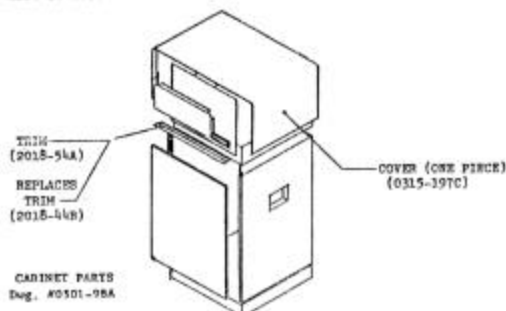

### CHANGE EFFECTIVE WITH SERIAL #3135

ALC control transferred from power supply to amplifier panel.